

**XGPON1 Burst Mode OLT SerDes**

**10G TX/2.5G RX Burst Mode SerDes for XGPON1 OLT**

**GENERAL DESCRIPTION**

K-Micro's XGPON1 OLT SerDes IP including 2.5Gb/s Burst Mode CDR (BMCDR) is now available for ASIC integration. The BCDR is able to achieve lock time of 16 less than bits, fastest in the industry, allowing system designers to maximize upstream bandwidth efficiency. In addition, K-micro's low jitter PLL enables the CDR to tolerate high amounts of data jitter and keeps the downstream generated jitter to well below XG-PON1 standard, G.987.2, defined by ITU-T Q2/SG15. Low jitter generation and high jitter tolerance enable this SerDes to be interoperable with any optical transceiver. A sample of XGPON1 OLT SerDes as well as an evaluation board is available for system evaluation. Figure 1 shows usage of XGPON1 OLT

**FEATURES**

- XGPON1 OLT SerDes
- Upstream: 2488.32 Mbps
- Downstream: 9953.28Mbps
- Fast lock in burst mode (less than 16 bits)
- 1.0V CML receiver
- 1.0V CML driver
- On chip 19.44MHz oscillator and optional 155.52 MHz external reference clock input
- Compatible with most optical transceivers
- At speed BIST to test burst mode performance
- Complies with ITU-T's G987.2 specifications

**BLOCK DIAGRAM**

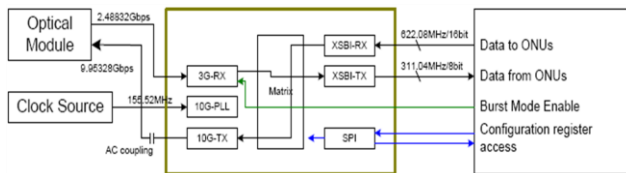

Figure 1 Usage of XGPON OLT SerDes

**EVALUATION BOARD**

The evaluation board shown in Figure 2 can be used to evaluate XGPON1 OLT SerDes's performance. This evaluation board can be interfaced with optical transceiver through SMA cables and with user logic, which will be programmed in FPGA, through 400-pin MegArray connector.

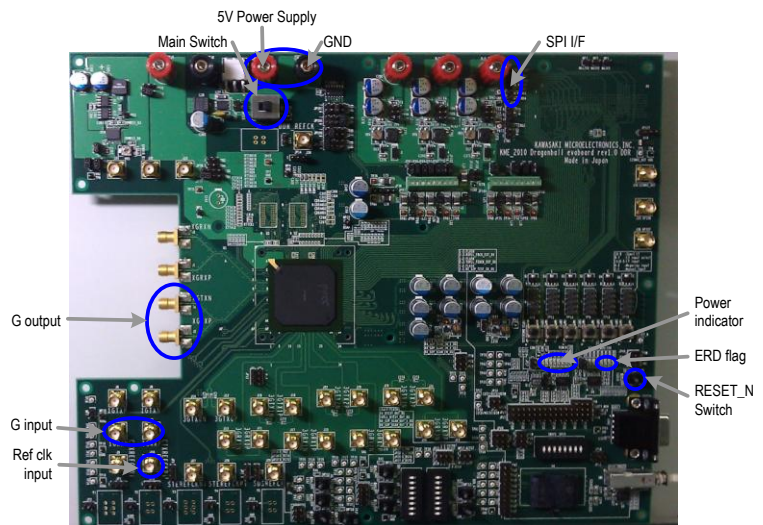

Figure 2 Picture of Evaluation Board

**Kawasaki Microelectronics, Inc.**

Makuhari Techno Garden B-11F  
**1-3, Nakase, Mihama-ku**  
 Chiba, 261-8501, Japan  
 Tel +81-43-296-7555  
 Fax +81-43-296-7419  
<http://www.k-micro.com/>

Kawasaki Microelectronics reserves the right to make changes to this document and to any products without notice.

**Kawasaki Microelectronics America**

2550 North First Street  
**Fifth Floor**  
 San Jose, CA 95131  
 Tel +1 (408) 570-0555  
 Fax +1 (408) 570-0567  
<http://www.k-micro.us>